

## Axial Live Tools for Haas Lathes

\*One (1) collet nut wrench and one (1) spanner wrench is included.

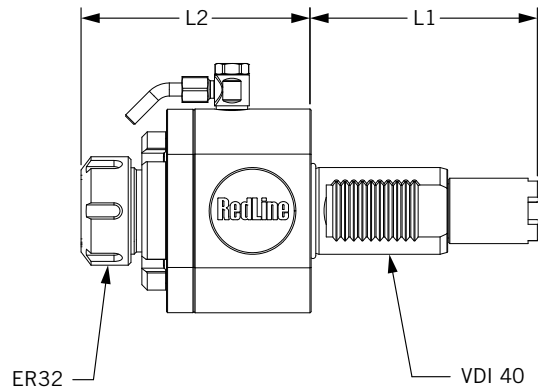

### VDI40 Axial Live Tools\*

Coolant Option: **External Coolant**

Part Number	Coupling	Nut	Collet	L1	L2	VDI	Max RPM	Drive Ratio	Runout
<a href="#">RHALT10532</a>	Short	External	ER32	105MM	112MM	40	6,000	1:1	≤.0002
<a href="#">RHALT11832</a>	Medium	External	ER32	118MM	112MM	40	6,000	1:1	≤.0002
<a href="#">RHALT13032</a>	Long	External	ER32	130MM	112MM	40	6,000	1:1	≤.0002

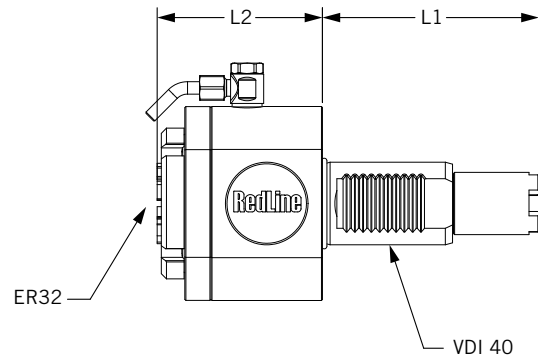

### VDI40 Axial Live Tools\*

Coolant Option: **External Coolant**

Part Number	Coupling	Nut	Collet	L1	L2	VDI	Max RPM	Drive Ratio	Runout
<a href="#">RHALT10532I</a>	Short	Internal	ER32	105MM	78MM	40	6,000	1:1	≤.0002
<a href="#">RHALT11832I</a>	Medium	Internal	ER32	118MM	78MM	40	6,000	1:1	≤.0002
<a href="#">RHALT13032I</a>	Long	Internal	ER32	130MM	78MM	40	6,000	1:1	≤.0002

Collets can be found on pages 50-66. For hardware visit page 44.

## Radial Live Tools for Haas Lathes

\*One (1) collet nut wrench and one (1) spanner wrench is included.

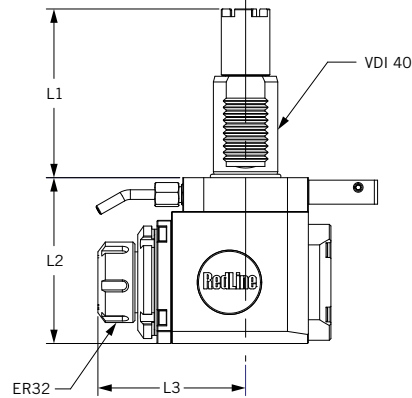

Radial Live Tools\*

Coolant Option: **External Coolant**

Part Number	Coupling	Nut	Collet	L1	L2	L3	VDI	Max RPM	Drive Ratio	Runout
<a href="#">RHRLT10532CW</a>	Short	External	ER32	105MM	103MM	84MM	40	6,000	1:1	≤.0002
<a href="#">RHRLT11832CW</a>	Medium	External	ER32	118MM	103MM	84MM	40	6,000	1:1	≤.0002
<a href="#">RHRLT13032CW</a>	Long	External	ER32	130MM	103MM	84MM	40	6,000	1:1	≤.0002

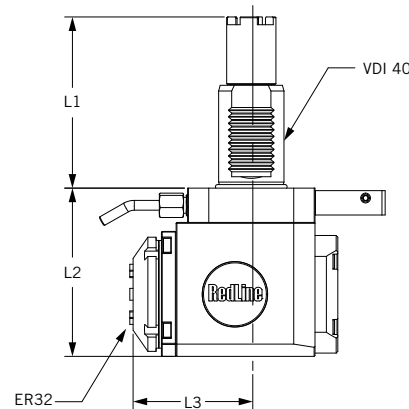

Radial Live Tools\*

Coolant Option: **External Coolant**

Part Number	Coupling	Nut	Collet	L1	L2	L3	VDI	Max RPM	Drive Ratio	Runout
<a href="#">RHRLT10532ICW</a>	Short	Internal	ER32	105MM	103MM	82MM	40	6,000	1:1	≤.0002
<a href="#">RHRLT11832ICW</a>	Medium	Internal	ER32	118MM	103MM	82MM	40	6,000	1:1	≤.0002
<a href="#">RHRLT13032ICW</a>	Long	Internal	ER32	130MM	103MM	82MM	40	6,000	1:1	≤.0002

Collets can be found on pages [50-66](#). For hardware visit page [44](#).